

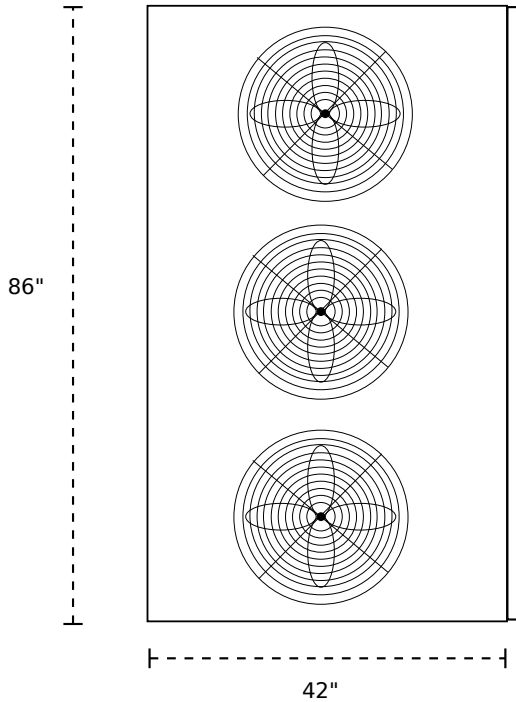

20 TON SPLIT DEHU

MODEL DU20T29CK696-4-SPLIT

TOP



SPECIFICATIONS:

- 20 ton dehumidifier
 - Performance: 27.8 gallons per hour @ 80F and 60% relative humidity
 - 29 gallons per hour, 696 gallons per day
 - 12.62 pints per KW
 - Electrical: 460-480V, 60hz three phase
 - Minimum Circuit Ampacity: 5, Maximum Fuse Size 15 Amps
 - R410a Refrigerant
 - Two remote condensers, specs on next page
 - Scroll Compressor, specs on next page
 - CFM: 6,000
 - Dimensions:
 - Inside unit 86" wide, 42" long, 48" tall
 - Outside remote units (2) each 35-1/2" wide, 35-1/2" long, 38-1/4" tall
 - Weight (LBS): 1405
 - Decibels: 84
- ADDITIONAL FEATURES:**
- Cold air discharge only inside.

SIDE

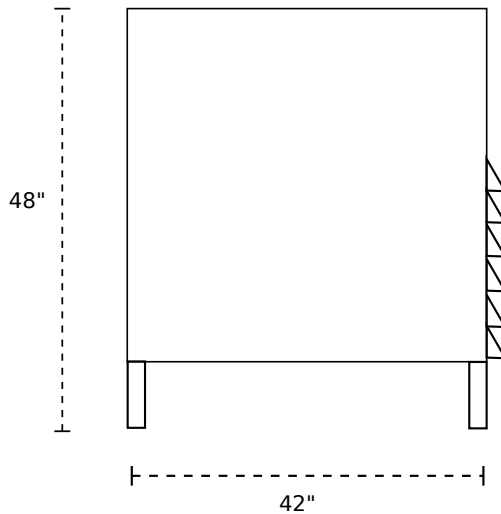

FRONT

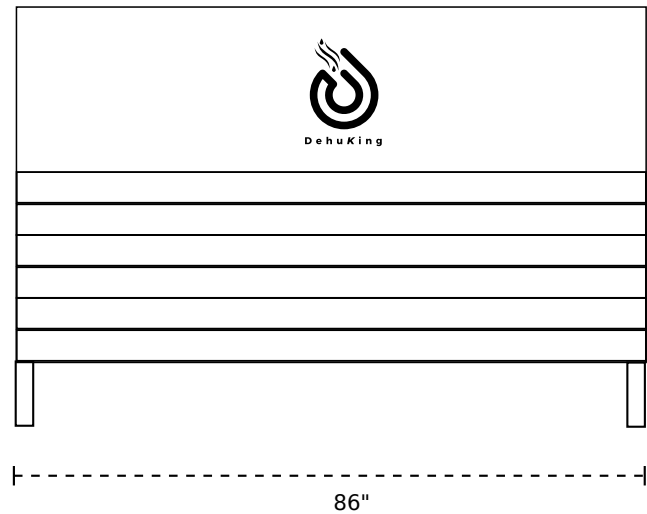



TOP

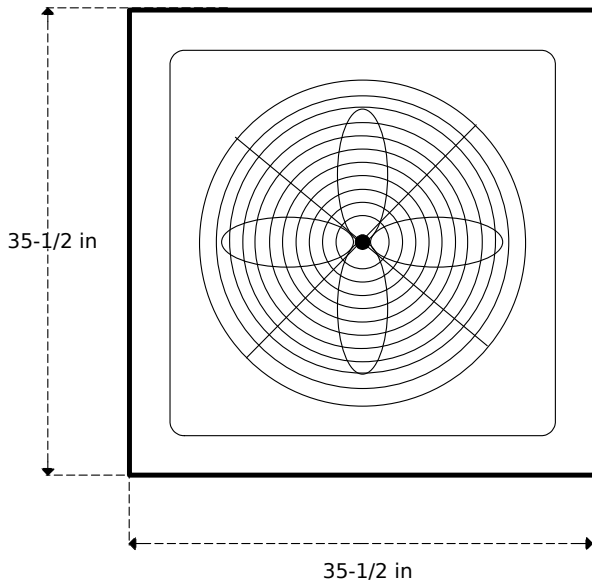

MODEL DU20T29CK696-4-SPLIT

- Two remote condensers each:
- Electrical: Voltage range 460-480V
- Minimum Circuit Ampacity: 22 Amps, Maximum Fuse Size 35 Amps
- Each with 120,000 BTU/HR Copeland scroll compressor
- Dimensions (each): 35-1/2" wide, 35-1/2" long, 38-1/4" tall
- Approximate shipping weight (LBS): 301 each
- Decibels: 72

FRONT

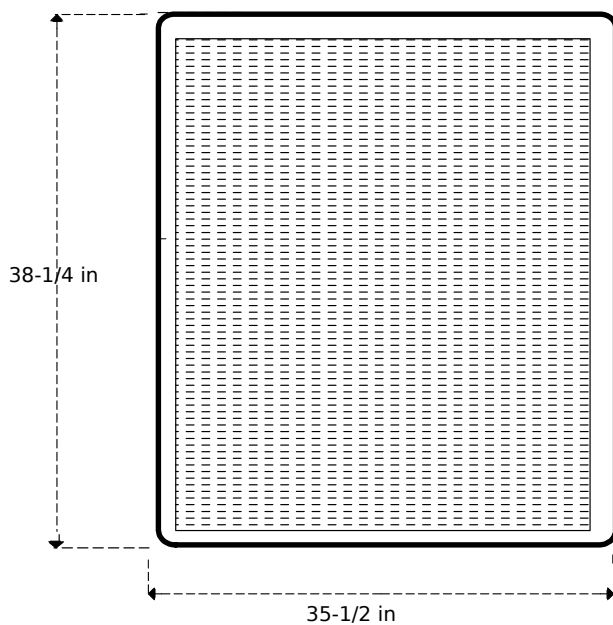

REAR

